

PRODUCT INFORMATION SHEET

# STAINLESS STEEL

# ENVIRONMENTAL TUBE HOUSING

## FEATURES

- F 316L Stainless Steel Construction for Harsh Environments
- IP68 Certified
- Easy to Install and Service
- Optional Germanium Window for Thermal Applications
- High-Quality Construction for Durability



[www.wrensolutions.com](http://www.wrensolutions.com)



PRODUCT INFORMATION SHEET



www.wrensolutions.com

Model Number	ETH12-SS
<b>CONSTRUCTION</b>	
Housing	Stainless Steel (316L)
Finish	Electropolished
Lens Window	Tempered Glass or Germanium
Weight	16.5lbs (7.5kg )
<b>ENVIRONMENTAL</b>	Indoor or Outdoor
Operating Range	-25°C - 50°C (-13°F - 122°F)
Heater	50W
Blower	1.6W @ 7.2 CFM
<b>CONNECTIONS / POWER</b>	
Input Voltage	24VAC
Power	2.1A (Heater On)

**MODELS**

- ETH12-TSSMA Stainless Steel Tube Housing (316L), with Sunshield and Tempered Glass Window
- ETH12-TSSMA-H Stainless Steel Tube Housing (316L), with Sunshield , Tempered Glass Window and Heater/Blower
- ETH12-GSSMA Stainless Steel Tube Housing (316L) for IR applications. Includes Sunshield, 50mm Germanium
- ETH12-GSSMA-H Stainless Steel Tube Housing (316L) for IR applications. 50mm Germanium Window, Heater/Blower

**ACCESSORIES**

- HM4100 Wall Mount

**DIMENSIONS**

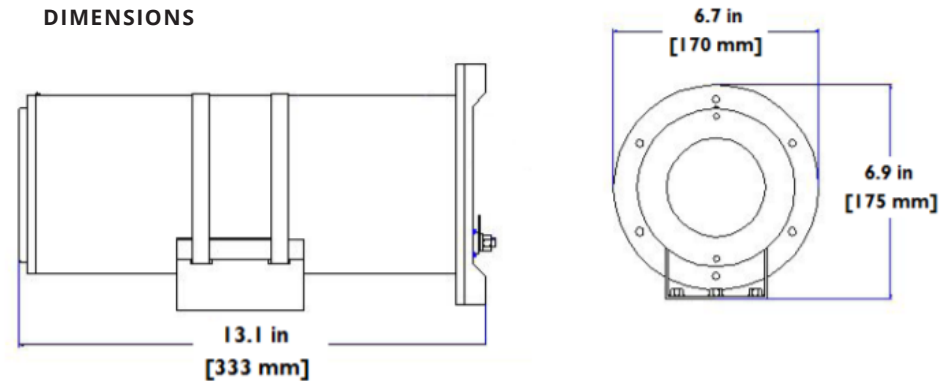

124 Wren Parkway, Jefferson City, MO 65109 USA  
 (800) 881-2249 • www.WrenSolutions.com

Wren,® the Wren logo, and Hyperion® are trademarks of Wren. The trademarks that are followed by ® are registered trademarks in the U.S. All other trademarks and/or registered trademarks mentioned herein are properties of their respective owners and are for reference purposes only. The use of such third party trademarks does not indicate any affiliation with or sponsorship of or by Wren Solutions. Copyright © 2021 Wren Solutions. All rights reserved.