

## SD6 Series

Housings > Indoor> Recessed/Pendant Mount > 6-inch Dome



### Features

- Metal back-box for plenum applications
- Functional design
- For indoor applications
- Recessed and pendant-mount options
- Accommodates fixed or PTZ cameras

The SD6 housings are available in both recessed and pendant mount options and are built with Wren's standard approach for simple installation. The units feature a plenum-rated metal back-box and the pendant-mount version utilizes standard 1.5-inch NPT for simple connections. Both models feature a 6-inch optically-correct dome and accept either fixed or pan-tilt-zoom cameras.

### Dimensions

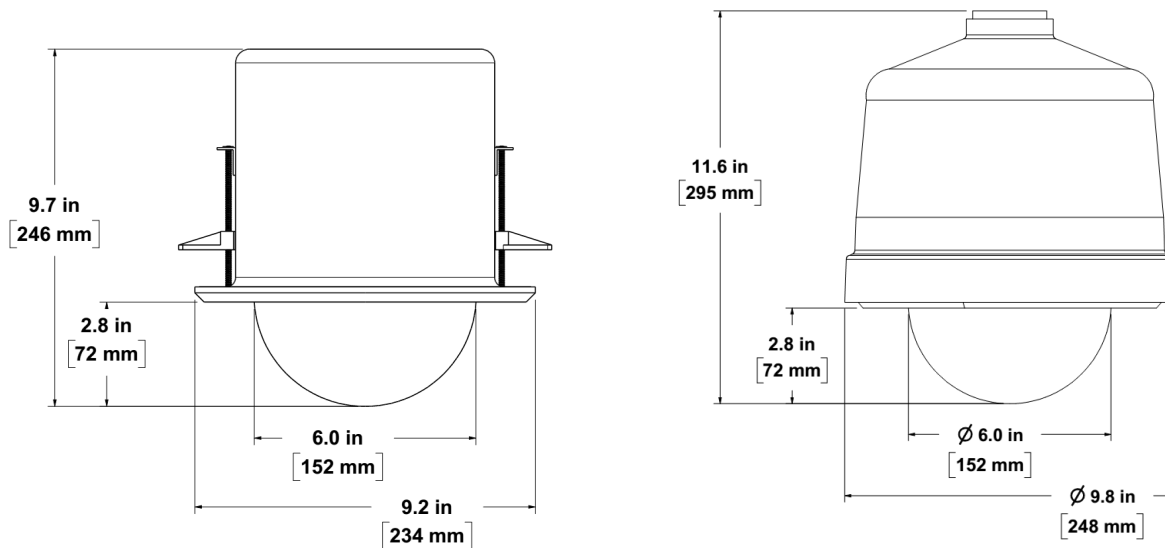

# PRODUCT SPECIFICATIONS

## General

### Construction

Backbox	Steel construction; black powder-coat
Shroud (SDP6)	High-Impact Polystyrene (HIPS)
Dome	Optical-grade polycarbonate
Trim Ring	ABS
Bracket	Heavy-gauge steel; black power-coat finish

### Weight (without camera)

SDR6	4.4lbs (2.0Kg)
SDP6	5.4lbs (2.45Kg)

## Models

SDR6CW-F	Recessed-mount, 6" Clear dome and with White trim ring for Fixed cameras
SDP6CW-F	Pendant-mount, 6" Clear dome and with White trim ring for Fixed cameras

## Supported Cameras

SDR6 and SDP6 accommodate fixed cameras with a Maximum Camera/Lens (MCL) length of 9"

## Environmental

Indoor

## Accessories

CTS6	Ceiling Tile Support Kit
------	--------------------------

Need a custom finish or custom design? Let us help.  
Visit us at [www.wrensolutions.com/custom](http://www.wrensolutions.com/custom)



124 Wren Parkway - Jefferson City, MO 65109 - (800) 881-2249 - [www.wrensolutions.com](http://www.wrensolutions.com)

Wren®, the Wren logo, and The Power to See Your Business are trademarks of Wren. The trademarks that are followed by ® are registered trademarks in the U.S. All other trademarks and/or registered trademarks mentioned herein are properties of their respective owners and are for reference purposes only. The use of such third party trademarks does not indicate any affiliation with or sponsorship of or by Wren. Copyright © 2015 Wren. All rights reserved.