

# MONITOR MOUNT SERIES - SMALL FORMAT

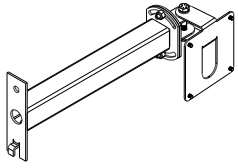

**MM-PVM08CWA-W**  
HORIZONTAL GONDOLA  
MOUNT

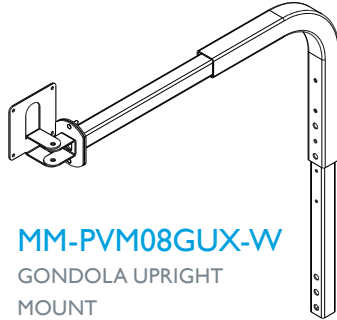

**MM-PVM08GUX-W**  
GONDOLA UPRIGHT  
MOUNT

## FEATURES

- Accommodates one Wren 7" or 10" PVM
- Easy Length and Rotational Adjustments
- Ideal for Merchandise Level Deterrent
- Tubular Construction Serves as Cable Conduit

## PRODUCT SPECIFICATIONS

MODEL	MM-PVM08CWA-W	MM-PVM08GUX-W
Product Name	Horizontal Gondola Mount	Gondola Upright Mount
Material	Carbon Steel	
Finish	Powder Coated, White	
Weight	4.0 lbs (1.8kg)	6.0 lbs (2.7kg)
Maximum Load	17.5 lbs (7.9 kg)	
Mount Pattern	VESA 75 x 75	
Environment	Indoor	

## DIMENSIONS

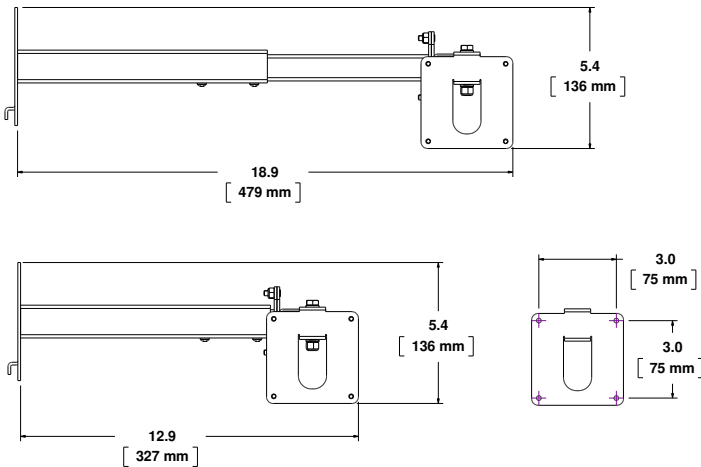

**MM-PVM08CWA-W**  
HORIZONTAL GONDOLA MOUNT

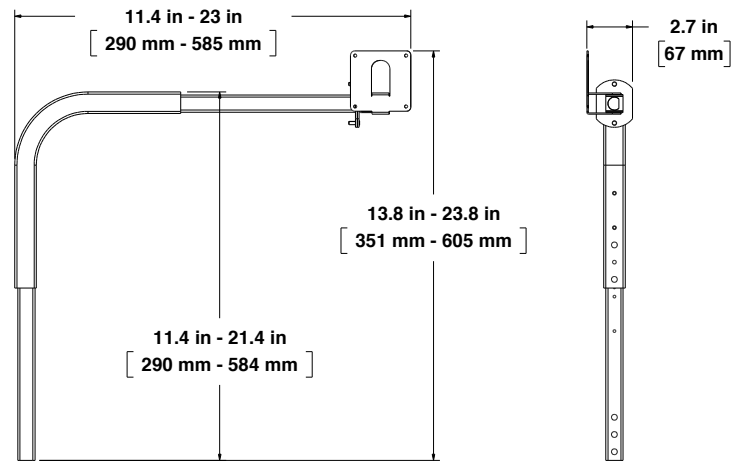

**MM-PVM08GUX-W**  
GONDOLA UPRIGHT MOUNT

124 WREN PARKWAY, JEFFERSON CITY, MO 65109 USA • (800) 881-2249 • [www.wrensolutions.com](http://www.wrensolutions.com)

Wren,® the Wren logo, and The Power to See Your Business are trademarks of Wren. The trademarks that are followed by ® are registered trademarks in the U.S. All other trademarks and/or registered trademarks mentioned herein are properties of their respective owners and are for reference purposes only. The use of such third party trademarks does not indicate any affiliation with or sponsorship of or by Wren. Copyright © 2018 Wren. All rights reserved. REV1811

